

STEEL SAFETY RAILING: VDKR-6

APPROX WEIGHT: 32.71 lbs.
 DOES NOT INCLUDE WEIGHT OF POWER OR PACKAGING!!!

*** ANY ADDITIONS, DELETIONS, OR OMISSIONS MUST BE CORRECTED ON THIS DRAWING AS THIS DRAWING WILL BE CONSIDERED ALL INCLUSIVE ***
 ALL GRAPHICS PROVIDED ARE FOR REFERENCE ONLY. IF CERTAIN DIMENSIONS ARE CRITICAL PLEASE VERIFY THOSE DIMENSIONS WITH YOUR SALESPERSON

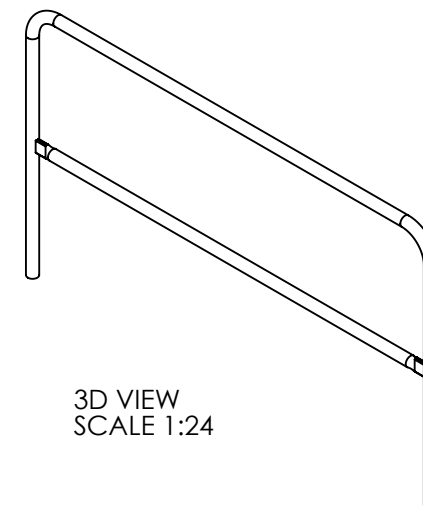
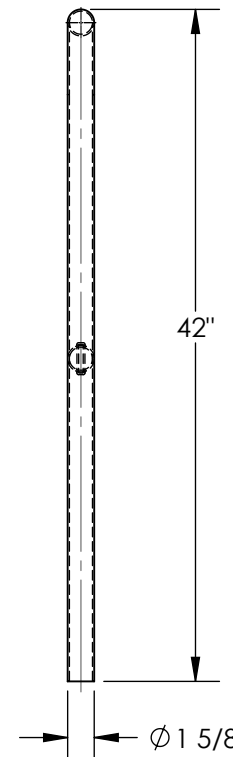
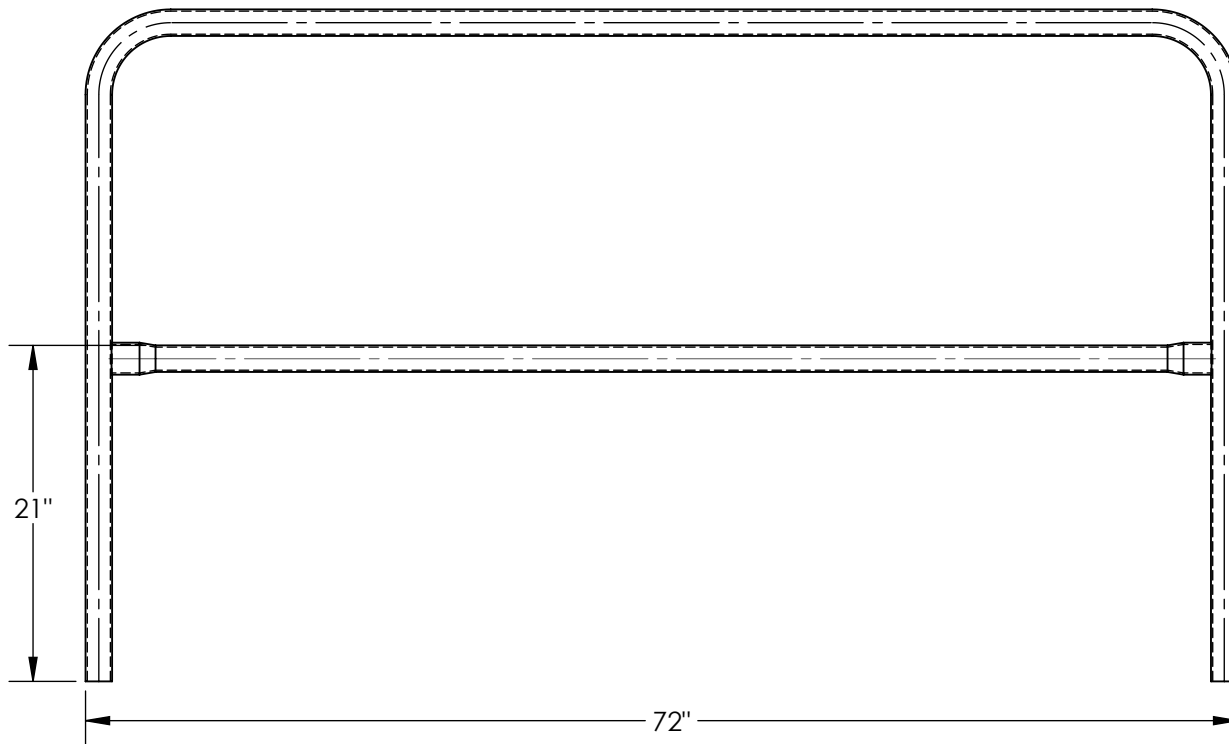

3D VIEW
 SCALE 1:24

STANDARD FEATURES

- MODEL NUMBER: VDKR-6
- TOP RAIL HEIGHT: 42"
- MID RAIL HEIGHT: 21"
- LENGTH: 72"
- HANDRAIL DIAMETER: $\varnothing 1 \frac{5}{8}$ "
- TOUGH BAKED IN POWDER COATED YELLOW FINISH

SPECIAL FEATURES

NONE

| | |
|---|--|
| FOR INTERNAL USE ONLY PROJECT SIGN OFF | |
| SALES | |
| ENG. | |
| FAB. | |
| POWER | |

I, THE UNDERSIGNED, AGREE THAT THE PRODUCT AS REPRESENTED SATISFIES DESIGN AND DIMENSION REQUIREMENTS. I ALSO ACKNOWLEDGE MY DUTY TO CONFIRM PRODUCT AND INSTALLATION COMPLIANCE WITH ALL APPLICABLE FEDERAL, STATE AND LOCAL REGULATIONS AND STANDARDS.

ANY MODIFIED UNITS ARE NON-RETURNABLE

[] As drawn [] As marked

Signed: _____ Date: _____

Printed Name: _____

LEAD TIME WILL START UPON RECEIPT OF SIGNED APPROVAL DRAWING

| | | |
|--|---|------------------------------------|
| DISTRIBUTOR'S NAME: | | P.O.# |
| VESTIL MANUFACTURING | | X |
| | | W.O.# |
| DRAWN BY: TAC REFERENCE: X QUOTED LEAD TIME: X | DATE: 11/1/2010 SCALE: 1:12 QUOTE # X | X X FILE NAME: 23-007-071 |